

APPLY LUBRICANT TO ALL SEALS
PRIOR TO INSTALLATION.
DO NOT USE SILICONE TYPE LUBRICANTS.
FOR PROPER ARM MOUNTING SEE IS1505.

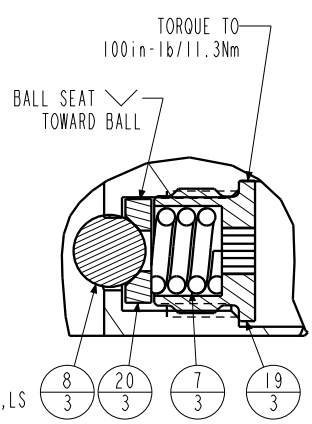

DETAIL A
SCALE 1.500

No.	QTY	PART No.	DESCRIPTION	Std. Seal Kit	FKM Seal Kit
N/A	N/A	IS1505	INSTRUCTION SHEET, ARM INSTALLATION		
N/A	N/A	6V711050	SEAL KIT, FKM		
N/A	N/A	60711050	SEAL KIT, STANDARD		
26	1	39V11051	WIPER, PRESS-IN, (1-1/2)	X	X
25	1	39V10029	WIPER, PRESS-IN, (1/4)	X	X
24	1	39H51002	O-RING, (-033)	X	39V51002
23	1	91100001	MAGNET, .130 x .312, PS		
22	1	81592136	CAM, SC, LP, 7500/33KN, RH, LS, TC, PR		
21	1	81542112	BASE, SC, BF, LP, 33KN, PR		
20	3	81532108	SEAT, BALL, SC, LP, TC		
19	3	81532107	RETAINER, SC, LP, TC		
18	1	81500062	HOUSING, PS, MAG, SC, LP, LS		
17	1	81500060	ADAPTOR, PS, MAG, SC, LP		
16	2	43068006	PLUG, 1/4 BSPF MALE		
15	1	39054017	BU RING, (-033)	X	39054023
14	1	39054016	BU RING, (1.5x.125x.063)	X	X
13	1	39052043	SEAL, LL, (1/4 X 1/8 X 1/8 X 1/2)	X	39V52043
12	1	39052030	SEAL, CROWN, 1-3/4x2-1/8x1/4	X	39V52030
11	2	39051041	O-RING, (-006)	X	39V51041
10	2	39050042	O-RING, (-011)	X	39051025
9	1	39011075	SEAL, LL, (1-1/2 X 1/8 X 1/8 1-3/4)	X	39V11075
8	3	23650004	BALL, TUNGSTEN-CARBIDE. 250		
7	3	23350066	SPRING, COMPRESSION		
6	10	21500305	SHCS, M8 X 1.25-6G X 30MM		
5	2	21500200	WASHER		
4	1	21500044	SCREW, CAP, BTNH, M3-0.5 X 6, SSTL		
3	3	21500043	SHCS, M3-0.5 X 6 ALY		
2	3	21500031	SHCS, M5 X 0.8 X 14, ALY		
1	2	21500019	SCREW, CAP, BTNH, M3 X 6, ALY		

PARTS LIST



VEKTEK, INC.
1334 E. SIXTH AVE. P.O. BOX 625
EMPORIA, KS. 66801 U.S.A.

ASSEMBLIES AFFECTED	PARTS LIST, ASSY, SC, LP, TC, BF, 33KN, DA, RH, LS, PS
41423326PS	
41423326PSF	
SIZE A	MPLV7258
REV C	

C	5762	RELEASE	JDW	07/18/25
REV	IN ACCORDANCE WITH ECN	EFFECTIVE DATE	REVISED BY	DATE
DRW BY:	JDW	DRAWING STATUS: Released		
DATE:	03/04/19	PRODUCTION APPROVED FOR RELEASED STATUS ONLY		

SHEET 1 OF 1

